

FVR 900 FREIGHTER TURBO

Engine

Model	ISUZU 6SD1-TC
Type	Turbocharged & intercooled
No. of cylinders	6 in-line
Bore x stroke (mm)	120 x 145
Displacement (cm ³)	9,839
Weight (kg)	720
Compression ratio (:1)	16.5
*Output (kW @ r/min)	199 @ 2,200
* Torque (N.m @ r/min)	1,000 @ 1,500
* ISO rating	

Clutch

Make/Model	DAIKIN
Type	Ceramic plate
Diameter (mm)	380
Operation	Air assisted

Transmission

Make/Model	ZF 9S-109
Ratios (:1)	
• 1st	10.245
• 2nd	6.573
• 3rd	4.705
• 4th	3.529
• 5th	2.610
• 6th	1.862
• 7th	1.353
• 8th	1.000
• 9th	0.739

Front Axle

Type	Reverse Elliot I-beam
------	-----------------------

Rear Axle

Type	Single banjo, fully floating
Final drive ratio (:1)	5.571

Performance

Maximum speed (km/h)	104.4
Gradeability (%)	54.2

Suspension

Front	Semi-elliptical leaf springs
Rear	Semi-elliptical leaf springs

Brakes

System	Full air
Park brake	Air acting on rear wheels
Total friction area (cm ²)	5,228

Steering

Ratio (:1)	22.4
Operation	Power

Cab

Control	Forward
Tilt	Yes

Wheels

Type	Radial
Tyres:	
• Front	12R22.5-16PR
• Rear	12R22.5-16PR
Rims:	
• Front	8.25 X 22.5
• Rear	8.25 X 22.5

Fuel tank

Capacity (litres)	400
-------------------	-----

Electrical system

System voltage (V)	24
--------------------	----

ISUZU
TRUCKS

Disclaimer: All specifications are subject to change without notice. While due caution has been exercised in the production of this document, Isuzu Truck South Africa does not accept liability whatsoever for any errors or omissions.

FVR 900 FREIGHTER TURBO

Vehicle Dimensions (mm)

AOL	Overall length	9,270
OW	Overall width	2,400
OH	Overall height	2,800
WB	Wheelbase	5,550
CE	Cab to chassis end	7,290
CA	Cab to rear axle	4,840
FOH	Front overhang	1,270
ROH	Rear overhang	2,450
GP	Body gap	295
BW	Rear axle width	2,465
AW	Front track	1,990
CW	Rear track	1,855
EH	Chassis rear end height	1,095
CWF	Front chassis width	850
CWR	Rear chassis width	850
HH	Rear ground clearance	235

Vehicle Masses (kg)

Manufacturer's GVM	16,000
Permissible gross mass (V)	16,000
Manufacturer's GCM	32,000
Permissible combination mass (D/T)	32,000
Chassis cab weight	5,140
Unladen:	
• Front	3,170
• Rear	2,240
Body and payload	10,590
Gross axle mass load – front (GA ¹)	7,100
Gross axle mass load – rear (GA ²)	10,500
Permissible axle load – front (A ¹)	7,100
Permissible axle load – rear (A ²)	9,000
Tyre capacity – front	7,100
Tyre capacity – rear	12,600

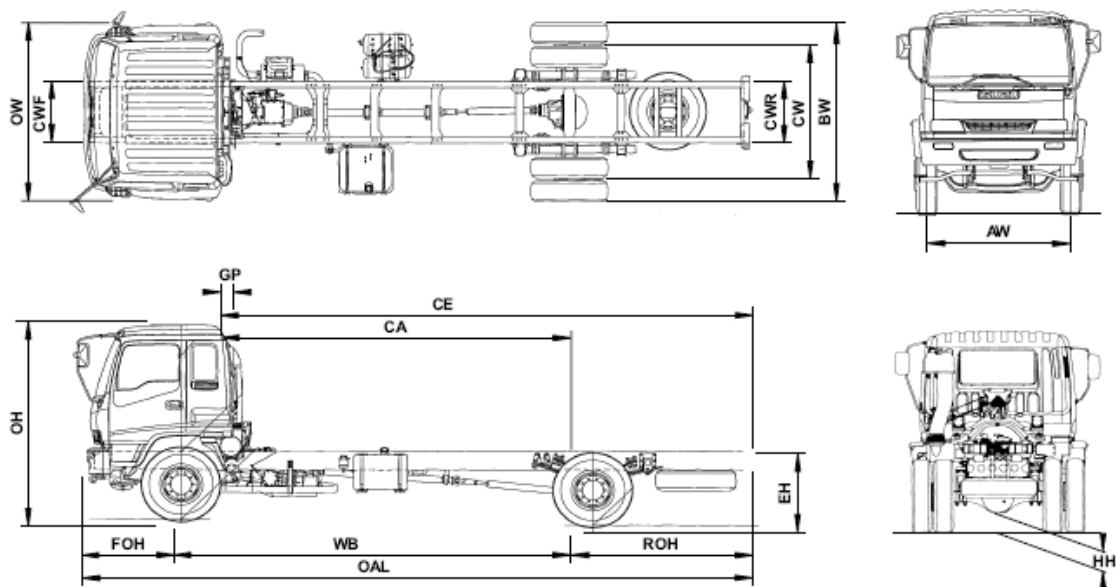

ISUZU
TRUCKS

Disclaimer: All specifications are subject to change without notice. While due caution has been exercised in the production of this document, Isuzu Truck South Africa does not accept liability whatsoever for any errors or omissions.