

FVZ 1600 COMPACTOR TURBO (6 x 4)

Engine

Model	ISUZU 6SD1-TC
Type	Turbocharged & intercooled
No. of cylinders	6 in-line
Bore x stroke (mm)	120 x 145
Displacement (cm ³)	9,839
Weight (kg)	720
Compression ratio (:1)	16.5
*Output (kW @ r/min)	199 @ 2,200
* Torque (N.m @ r/min)	1,000 @ 1,500
* ISO rating	

Clutch

Make/Model	DAIKIN
Type	Ceramic plate
Diameter (mm)	380
Operation	Air assisted

Transmission

Make/Model	ZF 9S-109
Ratios (:1)	
• 1st	10.245
• 2nd	6.573
• 3rd	4.705
• 4th	3.529
• 5th	2.610
• 6th	1.862
• 7th	1.353
• 8th	1.000
• 9th	0.739

Front Axle

Type	Reverse Elliot I-beam
------	-----------------------

Rear Axle

Type	Single banjo, fully floating
Final drive ratio (:1)	5.571

Performance

Maximum speed (km/h)	104
Gradeability (%)	48.1

Suspension

Front	Semi-elliptical leaf springs
Rear	Semi-elliptical leaf springs

Brakes

System	Full air
Park brake	Air acting on rear wheels
Total friction area (cm ²)	8,048

Steering

Ratio (:1)	22.4
Operation	Power

Cab

Control	Forward
Tilt	Yes

Wheels

Type	Radial
Tyres:	
• Front	12R22.5-16PR
• Rear	12R22.5-16PR
Rims:	
• Front	8.25 X 22.5
• Rear	8.25 X 22.5

Fuel tank

Capacity (litres)	400
-------------------	-----

Electrical system

System voltage (V)	24
--------------------	----



Disclaimer: All specifications are subject to change without notice. While due caution has been exercised in the production of this document, Isuzu Truck South Africa does not accept liability whatsoever for any errors or omissions.

FVZ 1600 COMPACTOR TURBO (6 x 4)

Vehicle Dimensions (mm)

AOL	Overall length	9,805
OW	Overall width	2,400
OH	Overall height	2,800
WB	Wheelbase	5,700
CE	Cab to chassis end	7,765
CA	Cab to rear axle	4,990
FOH	Front overhang	1,270
ROH	Rear overhang	2,125
GP	Body gap	295
BW	Rear axle width	2,465
AW	Front track	1,990
CW	Rear track	1,855
EH	Chassis rear end height	1,100
CWF	Front chassis width	850
CWR	Rear chassis width	850
HH	Rear ground clearance	270

Vehicle Masses (kg)

Manufacturer's GVM	26,000
Permissible gross mass (V)	26,000
Manufacturer's GCM	34,000
Permissible combination mass (D/T)	34,000
Chassis cab weight	7,280
Unladen:	
• Front	3,240
• Rear	4,040
Body and payload	18,720
Gross axle mass load – front (GA ¹)	7,100
Gross axle mass load – rear (GA ²)	20,400
Permissible axle load – front (A ¹)	7,100
Permissible axle load – rear (A ²)	18,000
Tyre capacity – front	7,100
Tyre capacity – rear	25,200

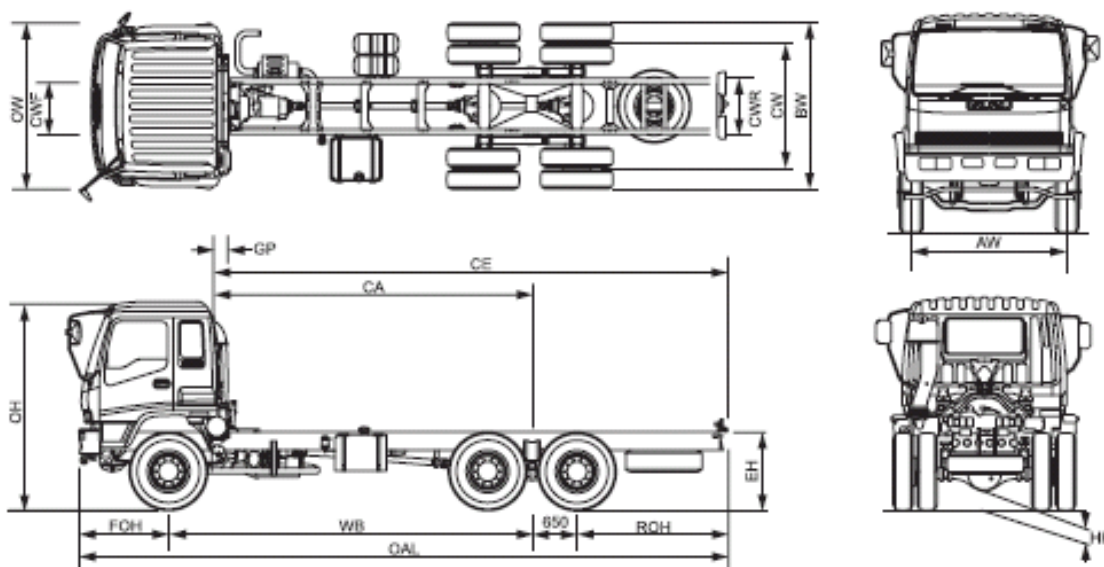

ISUZU
TRUCKS

Disclaimer: All specifications are subject to change without notice. While due caution has been exercised in the production of this document,

Isuzu Truck South Africa does not accept liability whatsoever for any errors or omissions.