

ISUZU GIGAMAX

GIGAMAX 70 - 460

ENGINE		
Model		6WG1-TCC
Type		TURBO CHARGED & INTERCOOLED
Fuel Injection		EURO III COMMON RAIL DIESEL
No. of Cylinders		6
Bore x Stroke	(mm)	147 x 154
Displacement	(cm ³)	15,681
Compression Ratio	(:1)	17.0
Output	(kW @ r/min)	338 @ 1,800
Output	(ps @ r/min)	460 @ 1,800
Torque	(Nm @ r/min)	2,157 @ 1,300
TRANSMISSION		
Model		MJX16P
Type		16-SPEED AUTOMATED MANUAL
Retarder		VOITH VR115 HR HYDRAULIC
CLUTCH		
Make / Model		SACHS
Type		TWIN DRY PLATES
Diameter	(mm)	390 (15")
Operation		HYDRAULIC WITH AIR ASSIST
SUSPENSION		
Front		TAPER LEAF
Rear		4 BAG AIR / AXLE
BRAKES		
System		FULL AIR
Park Brake		AIR ACTING ON REAR WHEELS
Total Friction Area	(cm ²)	2,400
CAB		
Control		FORWARD
Tilt		ELECTRIC
WHEELS & TYRES		
Type		RADIAL
Tyre Size	(Front)	315/80R22.5
Tyre Size	(Rear)	315/80R22.5
Wheel Size	(Front)	9.00 x 22.5
Wheel Size	(Rear)	9.00 x 22.5
FUEL TANK		
Capacity	(Litres)	1,000
FRONT AXLE		
Model		MERITOR MFS73
REAR AXLE		
Model		MERITOR RT46-160P
Final Drive Ratio	(:1)	4.300
ELECTRICAL SYSTEM		
		24 VOLT
MASS DATA (kg)		
Manufacturer's GCM		70,000
Permissible Combination Mass (D/T)		70,000
Manufacturer's GVM		26,000
Permissible Gross Mass (V)		25,500
Front Axle Tare Mass		4,904
Rear Axle Tare Mass		3,776
Total Tare Mass		8,680
Gross Axle Mass Load - Front (GA1)		7,500
Gross Axle Mass Load - Rear (GA2)		21,000
Permissible Axle Load - Front (A1)		7,500
Permissible Axle Load - Rear (A2)		18,000
Tyre Capacity - Front		8,000
Tyre Capacity - Rear		29,200
Approx. Body & Payload		47,320

Major features

- Cruise control
- Lockable 1,000 litre fuel tanks
- 315/80 R22.5 Steering & driving tyres
- Radio/CD player
- Climate control
- ABS brakes with EBD and ASR
- Disc brakes all round with brake pad wear indicators
- ISRI air suspension seat with integrated safety belt
- Driver's SRS airbag
- Power windows
- Central door locks
- Cab perimeter curtains with divider
- Rear suspension height adjustment controls
- Voith VR115 HR hydraulic retarder
- 16 speed Automated Manual Transmission with skip shift and power/economy modes
- Speed limiting device
- Electric cab lifting/tilting device
- Air suspended cab
- A multitude of storage facilities
- 360° cab interior curtains

The full truck-tractor package includes:

- Jost 37C 5th wheel
- Catwalk
- Toolbox
- Chevron board
- Suzi couplings and electrical trailer connections plus ABS connection
- Rear working light
- Single Sleeper Bunk (650mm x 2,400mm)

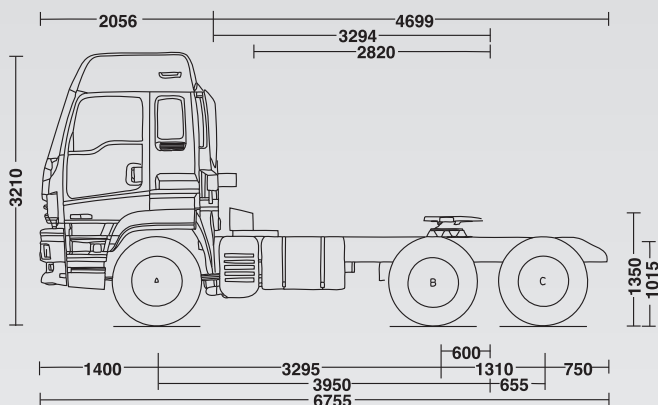
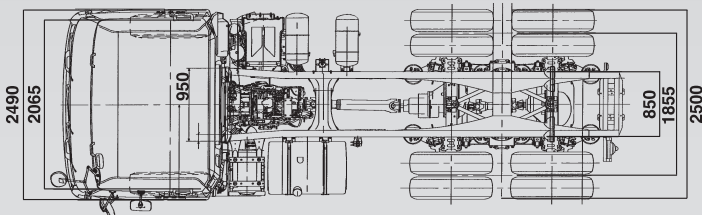

Standard OEM 5th Wheel (Jost 37C) is limited to 65,000kg combination mass.

For more information, call us on **08600 47898 (ISUZU)**, visit www.isuzutrucks.co.za or your nearest Isuzu Truck dealer.

ISUZU
TRUCKS
For the long run

Specifications are based on the information available at the time of printing and are subject to change. Optional accessories available at extra cost.